

ART 912NPT

Stainless Steel 2 Piece Ball Valve



Technical data

Max pressure: 140 Bar

Working temp: -25°C to +200°C

Features

- NPT Ends (ANSI B1.20.1)
- Full bore
- 2000 PSI rated
- Locking device

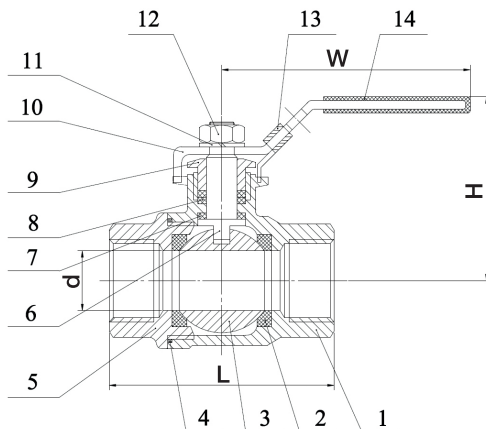

DN	1/4"	3/8"	1/2"	3/4"	1"	1 1/4"	1 1/2"	2"
d	11.5	12.5	15	20	25	32	40	50
L	49	49	58	65	77	90	105	125
H	54	54	56	65	70	75	93	99
W	105	105	105	118	150	150	182	182
N.m	4	4	5	8	10	14	18	25
Kv	6.0	16.0	35.0	46.0	72.0	105.0	170.0	275.0
Kgs	0.23	0.23	0.31	0.55	0.74	1.21	1.86	2.97

N.	Part Name	Materials
1	Body	CF8M
2	Ball Seat	R-PTFE (15%)
3	Ball	Stainless Steel 316
4	Body Gasket	PTFE
5	Cap	CF8M
6	Stem	Stainless Steel 316
7	Thrust Washer	PTFE
8	Stem Packing	PTFE
9	Gland Nut	Stainless Steel 304
10	Handle	Stainless Steel 304
11	Spring Washer	Stainless Steel 304
12	Nut	Stainless Steel 304
13	Lock Device	Stainless Steel 304
14	Handle Cover	Plastic

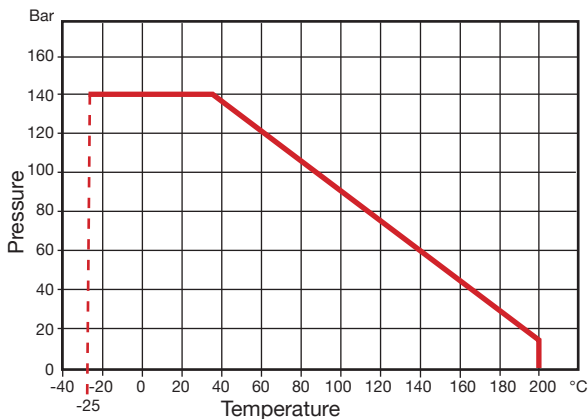

V1. Dimensions in mm

This data sheet is designed as a guide and should not be regarded as wholly accurate in every detail. We reserve the right to amend the specification of any product without notice.